

# Authorized Field Change

AFC 10912

**Date:** November, 2010

**Subject File:** BUS BODY

**Subject:** Body Isolators on BE and CE Buses

Model: BE Bus

Start Date: 09/01/2008 End Date: 05/28/2009

Model: CE Bus

Start Date: 09/01/2008 End Date: 05/28/2009

## DESCRIPTION

Certain BE and CE buses built with formed rubber body isolator pads between 9/1/2008 and 5/28/2009 may experience cracking and/or splitting pads, resulting in complete pad failure.

This campaign will require the inspection of the vehicle's isolator pads. If the vehicle is equipped with formed rubber body isolator pads, the pads will be replaced with fiber reinforced rubber isolator pads (Figure 1 and Table 1). Each kit in Table 1 contains 10 reinforced isolator pads and clips. The number of kits required for a specific vehicle is determined by the number of formed rubber body isolator pads found on that vehicle.

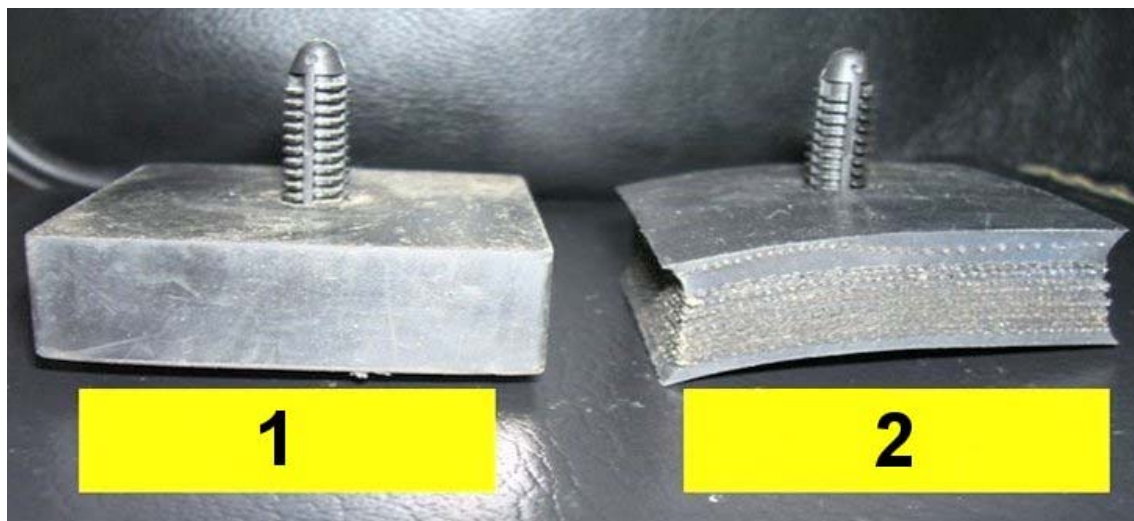

**Figure 1 Body Isolator Pads and Clips**

1. FORMED RUBBER ISOLATOR PAD (ORIGINAL)
2. REINFORCED RUBBER ISOLATOR PAD (NEW)

## PARTS INFORMATION

**NOTE – At the release of this campaign, parts availability will be limited. Please limit your orders to your immediate repair needs.**

## PARTS INFORMATION (CONT.)

Table 1 **Parts Information**

Part Number	Description	Quantity
8000913R91	Body isolator kit, BE and CE Buses	As Required
	– Body isolator pad	10
	– Christmas tree clip	10

## PROCEDURE

 **WARNING** – To prevent vehicle damage, personal injury, or death, park the vehicle on a flat, level surface. Make sure the engine ignition is in the off position, and the transmission is in neutral or in the park position, if the vehicle is equipped with an automatic transmission. Set the parking brake, chock the wheels, and disconnect the batteries at the negative terminal before doing any service procedures on the engine or vehicle.

 **WARNING** – When working around or under the vehicle, block the wheels to prevent the vehicle from moving in both directions. When raising the vehicle, support the vehicle with safety stands. Do not work under a vehicle supported only by jacks. Jacks can slip and fall over. Failure to follow this warning could result in property damage, personal injury or death.

 **WARNING** – To prevent personal injury or death, always wear safe eye protection when performing vehicle maintenance.

1. Verify that wheel chocks have been placed on the front wheels.
2. Inspect the isolator pads (Figure 1) at both the main body sills and the intermediate body sills (Figure 2).  
NOTE: It is not necessary to check every pad location. Normally, enough body sills are visible through the rear wheel wells to determine which type of pads are present at both main and intermediate body sills.
  - If the vehicle has fiber reinforced isolator pads at both the main sills and the intermediate sills, no action is required.
  - If the vehicle has fiber reinforced isolator pads at the main sills only, and formed rubber pads at the intermediate sills, the formed rubber pads will require replacement. Proceed to Step 3.
  - If the vehicle has formed rubber isolator pads at all pad locations, all pads will require replacement. Proceed to Step 3.

## PROCEDURE (CONT.)

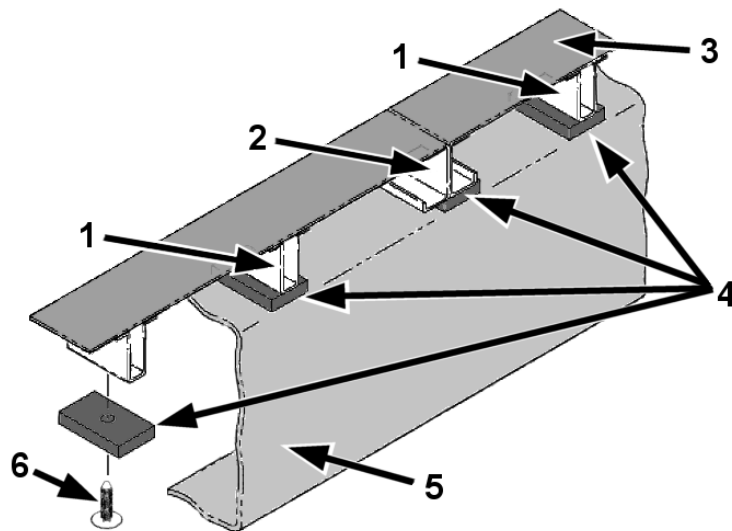

**Figure 2 Inspect Isolator Pads at Main and Intermediate Body Sills**

1. INTERMEDIATE BODY SILL
2. MAIN BODY SILL
3. FLOORING
4. ISOLATOR PADS
5. FRAME RAIL
6. CHRISTMAS TREE CLIP

**NOTE – In the following step it is not necessary for the tires to be off of the ground as long as the suspension load is removed.**

3. Using a bumper style jack, raise the rear of the vehicle by placing the jack pads on the rear frame rails (Figure 3). This process will allow the spring or air suspension to hang below the frame, allowing maximum access to the body mounting hardware. **DO NOT USE THE BUMPER TO RAISE THE VEHICLE.**
4. Lower the frame rails onto safety stands and remove the bumper style jack.

## PROCEDURE (CONT.)



**Figure 3**

5. Remove all body tie-downs (Figure 4).

- U-bolts — use ratcheting box end wrench to remove completely.
- J-bolts — use air impact to remove completely
- Formed clips — use air impact with 18" extension to loosen enough to disengage clip from frame rail and rotate to allow for body separation (Figure 5).
- Body and cowl outrigger bolts — loosen.

## PROCEDURE (CONT.)

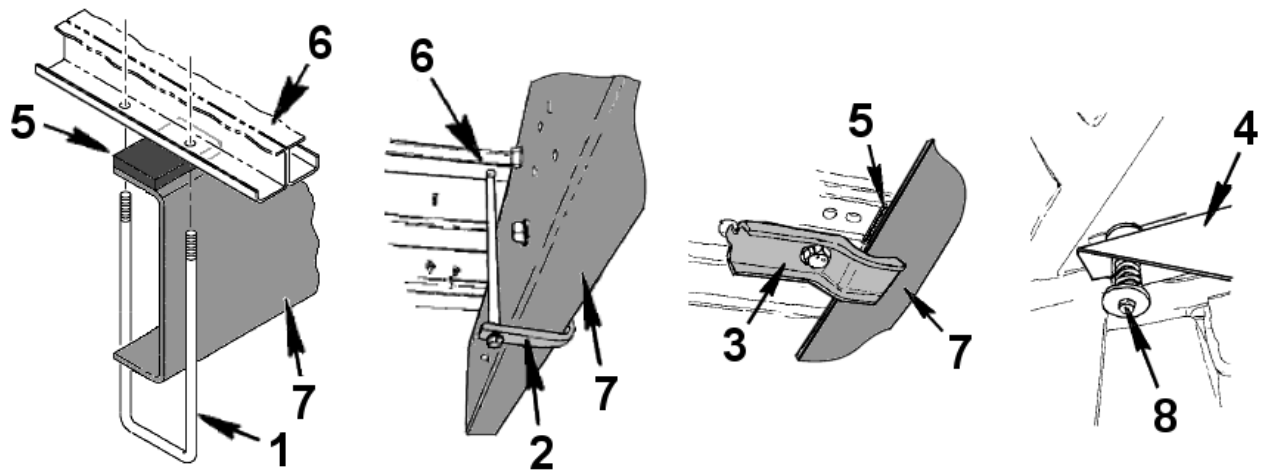

Figure 4 Body Tie-Downs

1. U-BOLT
2. J-BOLT CLIP
3. FORMED CLIP
4. OUTRIGGER BRACKET
5. ISOLATOR PAD
6. BODY SILL
7. FRAME RAIL
8. OUTRIGGER BOLT



Figure 5 Loosen Formed Clips and Rotate

**⚠ WARNING** – To prevent personal injury or death, completely drain all air tanks and air lines before disconnecting air lines or components.

## PROCEDURE (CONT.)

6. If the vehicle is equipped with air brakes, the air tank mounted inside the frame rail must be repositioned as follows:
  - A. Drain all air from the air tanks.
  - B. Remove the rear air line from the tank.
  - C. Loosen (do not remove) the four (4) air tank mounting nuts on the outside of the frame rail.
  - D. Remove the two (2) tie straps securing the harness and air lines to the air tank mounting bracket.
  - E. Remove the four (4) air tank mounting nuts and rotate the tank outboard of the frame rail and forward to position the tank away from the work area (Figure 6).



**Figure 6 Air Tank Repositioned**

7. Inspect all under body harness and hose routing to verify all clipping points will allow the body to be lifted 1.5 to 2.0 inches (3.8 to 5.1 cm) off of the frame rail. Remove or loosen any clipping points that will not allow the body to be lifted approximately 1.5 to 2.0 inches (3.8 to 5.1 cm) above the frame.
8. If the vehicle is equipped with a luggage box, or boxes, mounted with frame J-hooks, inspect the mounting to ensure the mounts do not limit the lifting process.
9. If the vehicle is equipped with a tail pipe which exits through the bumper, loosen the tailpipe brackets and clamps to allow the bumper to be lifted with the body.

**NOTE – In the following step, one (1) bolt should be left installed in each frame-to-bumper bracket.**

10. Loosen and remove two (2) of the three (3) mounting bolts securing the frame-to-bumper bracket to each of the frame rails (Figures 7 and 8). The weight of the body normally causes binding of the last mounting bolt, making it difficult to remove until the body weight is removed as the body is raised in Step 12.

## PROCEDURE (CONT.)

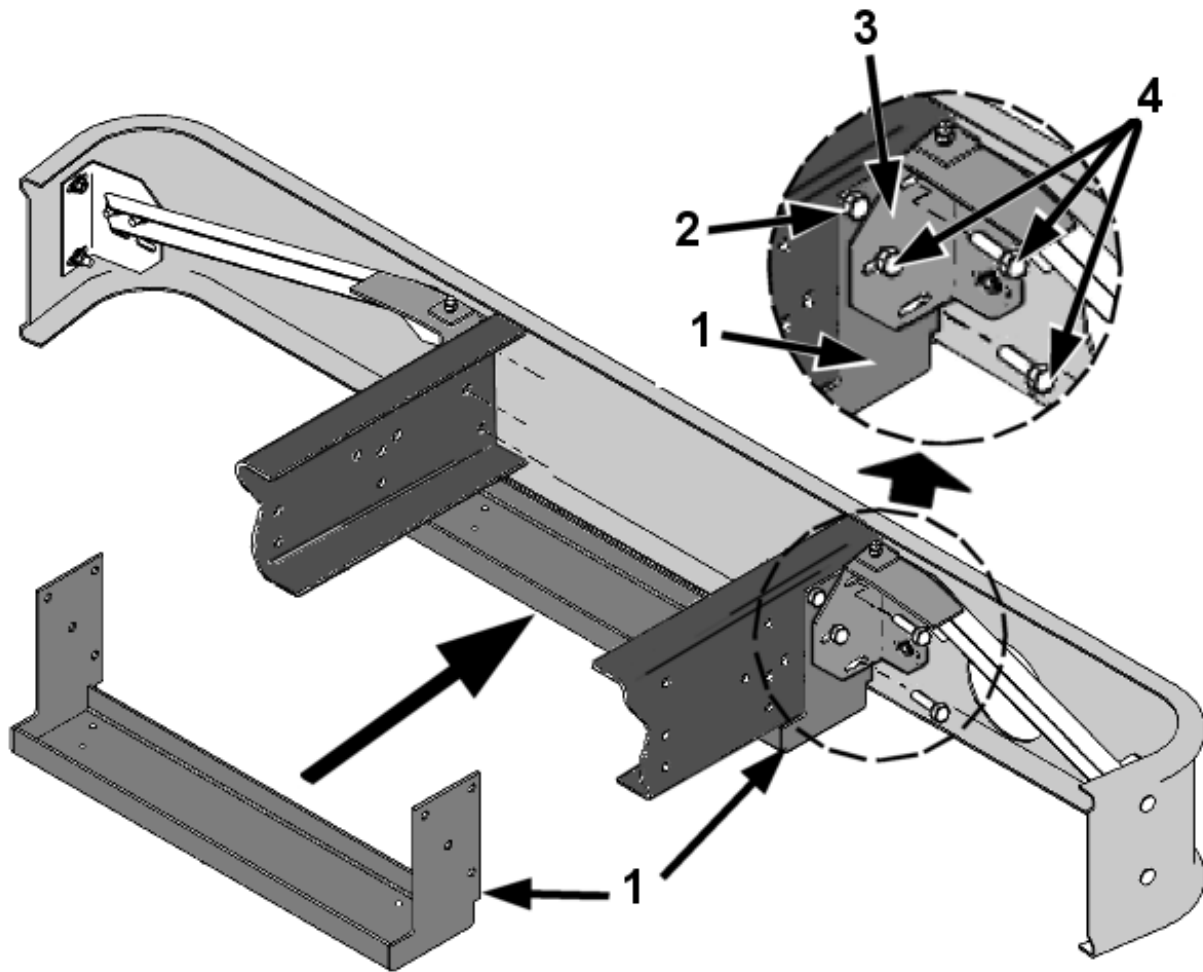

Figure 7 Bumper to Frame Rail Mounting Bracket

**⚠ WARNING** – To prevent personal injury or death, do not remove the mounting bolt that secures **ONLY** the tow hook plate to each frame rail. Removing these bolts would allow the tow hook plate to fall in a later step.

11. If the vehicle is equipped with a tow hook plate, the mounting bolts that secure **ONLY** the tow hook plate to the frame rails will not be removed (Figure 8). They will retain the tow hook plate in its original position to prevent it from falling and to keep the mounting holes aligned.

## PROCEDURE (CONT.)



**Figure 8 Frame Rail to Bumper Mounting Bracket with Tow Hook**

1. TOW HOOK PLATE
2. TOW HOOK PLATE MOUNTING BOLT
3. FRAME-TO-BUMPER BRACKET
4. FRAME-TO-BUMPER BRACKET MOUNTING BOLTS

**NOTE – In the following step, use a steel plate or other suitable material between the ram and the body sill to spread the ram load.**

**NOTE – In the following step, the bottom lip of the rear bumper may limit how far the body can be raised. If the bottom lip of the bumper contacts the frame rails, do not attempt to raise the body further.**

**NOTE – If the vehicle is equipped with a luggage box, or boxes, mounted with frame J-hooks, the mounts must be monitored during the lifting process to ensure the mounts do not limit the lifting process.**

12. Lift the body off of the frame rails as follows:

## PROCEDURE (CONT.)

- A. Using a steel plate or other suitable material between the ram and the body sill, position the ram (Figure 9) under the last main sill at the rear of the body (Figure 10).
- B. Using a suitable hydraulic ram, begin raising the body off of the frame rails.
- C. As the weight of the body on the frame is reduced, the remaining bolts securing the frame-to-bumper brackets to the frame rails must be removed.
- D. Raise the body off of the frame rails to allow approximately 2 inches (5.1 cm) of separation at the rear of the frame rails.



Figure 9 Typical Hydraulic Ram



Figure 10 Use a Suitable Plate to Spread the Load Over a Larger Area

**NOTE –** In the following step, remove the rearmost isolator pads even if they are reinforced rubber pads. They will be replaced with new reinforced rubber pads in a later step.

## PROCEDURE (CONT.)

13. Remove the rearmost isolator pads from above both frame rails and replace with a suitable support block approximately 2 inches (5.1 cm) thick (Figure 11). Lower the body on to the support blocks, but maintain some pressure on the hydraulic ram to help spread out the load.



**Figure 11 Use a suitable block to support the bus body while replacing the isolators**

**NOTE – Over 2/3<sup>rd</sup> of the vehicle’s isolators can normally be replaced with the rear of the body lifted.**

**NOTE – To improve the efficiency of the procedure, a new isolator pad should be installed at each location immediately after removing the old pad.**

14. Replace all formed rubber isolator pads accessible with the rear of the body lifted.
  - A. Start at the rear of the vehicle and work forward along both frame rails.
  - B. Use a hammer and scraper (Figure 12) to shear off the original pad and retainer.
  - C. Use angled needle nose pliers or similar tool to push old retainer from the floor sill hole if required (Figure 13).
  - D. On the main sills the isolator pad must be placed on the same flange as the tie-down.
  - E. Angled needle nose pliers and a pry bar (long and short) can be used to increase efficiency and to reach around the formed clip tie-downs (Figure 13).

**NOTE – Concerns about the condition of main and intermediate floor sills should be addressed by starting a Technical Service case file.**

## PROCEDURE (CONT.)



**Figure 12 Typical Tools for Replacing Isolator Pads**



**Figure 13 Use Angled Needle Nose Pliers or Pry Bars Where Necessary**

15. After replacing all of the accessible formed rubber isolator pads, use the ram to raise the rear of the body to allow the removal of the support blocks and the installation of the last two isolator pads.
16. As the body is lowered onto the frame rails:
  - A. Monitor all luggage boxes mounted with frame J-hooks, to ensure the mounts do not cause interference.
  - B. Insert the mounting bolts through the frame-to-bumper bracket as the holes align with the holes in the frame. Tighten snugly; final torque will be completed in step 27.
17. Move the hydraulic ram to the forward outer Left Hand (LH) K-frame area (just outboard of the body outrigger). Refer to Figures 14 and 15. The support plate is not used with the ram at this location.



## PROCEDURE (CONT.)

19. Replace the remaining formed rubber body isolators on the LH side.
20. Using the ram, raise the body enough to allow the removal of the support blocks; then lower the LH side of the body and remove hydraulic ram.

**NOTE – Additional jack points may be required on longer body lengths. Refer to the optional lifting points in Figure 14. Always place the ram at a main body sill and use a steel plate or other suitable material between the ram and the body sill to spread the ram load. After raising the body, always place support blocks between the body and frame rail before working on the isolator pads.**

21. Place the hydraulic ram at the forward outer Right Hand (RH) K-frame area (just outboard of the body outrigger) and lift the RH side of body approximately 1.75 inches (4.4 cm). Refer to Figures 14 and 16. Place support blocks between the body and frame rail, then lower the body on to the support blocks. Maintain some pressure on the hydraulic ram to help spread out the load.



**Figure 16 Ram Positioned to Raise RH Side**

22. Replace the remaining formed rubber body isolators on the RH side.
23. Using the ram, raise the body enough to allow the removal of the support blocks; then lower the RH side of the body and remove hydraulic ram.

**NOTE – Additional jack points may be required on longer body lengths. Refer to the optional lifting points in Figure 14. Always place the ram at a main body sill and use a steel plate or other suitable material between the ram and the body sill to spread the ram load. After raising the body, always place support blocks between the body and frame rail before working on the isolator pads.**

24. When all formed rubber body isolators have been replaced, reinstall all body tie-downs and torque to specification. Refer to Torque Table (Figure 17).
25. If any harness or hose clipping points were altered prior to raising the body, verify that they have been returned to original condition.
26. Torque all body and cowl outrigger bolts. Refer to Torque Table (Figure 17).

## PROCEDURE (CONT.)

27. Torque the bolts securing the frame-to-bumper brackets to the frame rails. Torque to 80 to 100 lbf-ft (108 to 135 N•m).
28. If the tail pipe brackets and/or clamps were loosened earlier, return them to their original condition.
29. If an air tank was moved earlier, reinstall the tank and reconnect all air lines in their original locations. Check all disturbed air connections for leaks, then torque tank mounting nuts to 80 to 100 lbf-ft (108 to 135 N•m)
30. Verify that any luggage boxes with J-hook mounting are mounted securely and the J-hooks are straight and tight. Torque to 12 to 15 lbf-ft (16 to 20 N•m).
31. **Final inspection.**
  - a. Verify that no harness or hose abrasion points have been introduced.
  - b. Verify that all isolator pads are positioned correctly.
  - c. Verify that all tie-downs are installed and properly torqued.

NOTE: All J-bolt and U-bolt tie-downs should be installed with little to no angle, in-line with the main sill, to ensure they will not shift and loosen.

- d. Verify that the frame-to-bumper bracket bolts are properly torqued.

## PROCEDURE (CONT.)

### Scheduled Maintenance

This unit has been repaired per IC Corporation LLC, AFC 10912. As part of the repair, the body isolator pads located between the bus body and chassis frame rails have been replaced.

As noted in the Operators Manual, the body tie-downs require the following maintenance.

- 1,000 miles — Torque all body tie-downs, shear bolts, and outrigger bolts, per Figure 17.
- Quarterly — Torque all body tie-downs, shear bolts, and outrigger bolts, per Figure 17.

**CAUTION** – To prevent floor sill/body damage, the tie down bolts must be properly torqued at the scheduled intervals.

The body tie down bolts should be torqued to their proper values within 30 days or 1,000 to 2,000 miles, and quarterly thereafter. The body tie downs must be torqued correctly for the application to eliminate floor sill/body damage. Torquing the body tie downs must be part of a normal preventive maintenance check.

The following torque chart (Figure 17) can be used as reference when performing the required maintenance on all IC Bus™ models.



	Application	Size	Lbf-ft	N·m
	Formed Tie Down	1/2 In. – 13 x 2 1/2 In.	30 - 40	40 - 54
	J-Bolt Tie Down	1/2 In. – 13 x 12 1/4 In.	30 - 40	40 - 54
	U-Bolt Tie Down	1/2 In. – 13 x 13 In.	30 - 40	40 - 54
	Front Cowl Application	1/2 In. – 13 x 4 In.	40 - 50	54 - 68
	Rear Application, RE Model	1/2 In. – 13 x 4 1/2 In.	40 - 50	54 - 68
	Outrigger, CE Model	1/2 In. – 13 x 5 1/2 In.	25 - 30	34 - 40
	BTR Tie Down, (Between The Rail Fuel Tank) and BE, CE and FE rear Shear Bolts	3/8 In. – 16 x 1 In.	30 - 40	40-54

Figure 17 Bus Body Tie Down Torque Chart

Operation number must appear on all claims.

**Table 2 Labor Information**

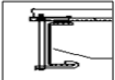
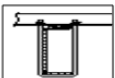
<b>Operation No.</b>	<b>Description</b>	<b>Time</b>
A40-10912-1	Inspect body isolator pads only. No service required.	0.2 hrs
A40-10912-2	Replace body isolator pads (38 to 48 pads).  BE/CE Bus, Feature Codes:  47AJL, 47AJU, 47AJN, 47AJP, 47AEB, 47AJT, 47AED, 47AEE, 47AJU, 47AEC	3.6 hrs
A40-10912-3	Replace body isolator pads (50 to 60 pads).  CE Bus, Feature Codes:  47AEG, 47AEH, 47AEJ, 47AEK, 47AEN, 47AEL, 47AEM, 47AEP	3.9 hrs
A40-10912-4	Replace body isolator pads (62 to 74 pads).  CE Bus, Feature Codes:  47AER, 47AES, 47AET, 47AEU, 47AEV, 47AEX, 47AEY, 47AEW, 47AEZ	4.2 hrs
A40-10912-5	Replace body isolator pads (76 to 88 pads).  CE Bus, Feature Codes:  47AGA, 47AGB, 47AGC, 47AGD, 47AGE, 47AGG, 47AGH, 47AGJ, 47AGK, 47AMG	4.6 hrs

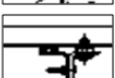
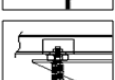
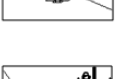
**ADMINISTRATIVE PROCEDURE**

Expense is to be charged to Warranty. Claims are to be submitted in the normal manner, making reference to Authorized Field Change Number G-10912.

It is important that the coding be completed properly to assist in processing the warranty claim. Complete instructions will be found in the Warranty Manual, Section 7-1. Special attention should be given to Items 39 through 44.

To assure this important improvement is made in a timely manner, all claims for G-10912 activity must be submitted by November 30, 2011 or within the normal warranty period for the vehicle, if after November 30, 2011.

GROUP				NOUN		C	WARR.	TP	PAD

GROUP Enter number G— \_\_\_\_\_

NOUN Leave blank \_\_\_\_\_

C (CAUSE) Enter either 1, 2, 3. (see below)

1. Inspected (No repair required).
2. Inspected and repaired.
3. Defective part from parts stock.

WARRANTY (Warranty Code) Enter 40. \_\_\_\_\_

TYPE PART Enter P for type part causing failure. \_\_\_\_\_

PAD Enter 100 \_\_\_\_\_

Distribution: All except J-81  
 Reproduction: Not required.

All trademarks are marks of their respective holders.